

**R140/170/225 Gasoline  
Engine (Vertical  
Shaft) Owner's  
Manual**

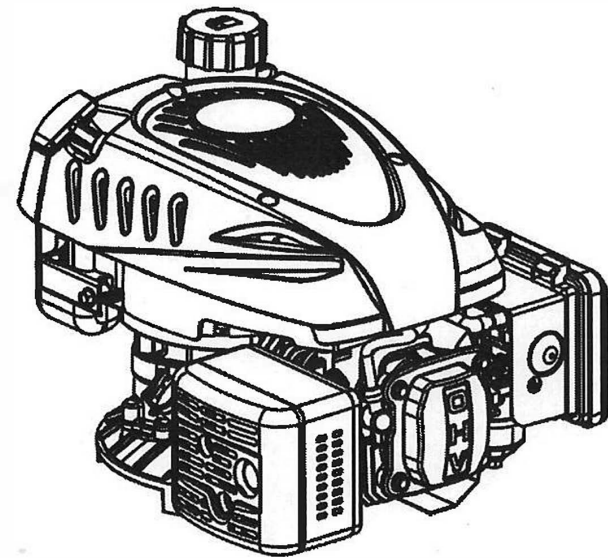



## **PREFACE**

Thank you for choosing a small general gasoline engine of our company.

The manual gives information with respect to operation and maintenance of the 140 170 225 general gasoline engine, and be sure to read it carefully first before operation. Only operate as the manual tells, can insure user's safety and get the best results of the engine operation. If a problem should arise or if you have any questions about your gasoline engine, consult an authorized our company servicing dealer.

The vertical shaft gasoline engine series products in this Owner's Manual are mainly used for the high pressure washer, lawn mower and mini tiller.

All information and diagrams of this manual are in accordance with the newest products at the publishing time. If revision and other change of the information described in this manual are a little different from the actual status, our company will explain it. Our company reserves the right to make change at any time without notice and without incurring any obligation. No part of this publication may be reproduced without written permission.

This manual should be considered a permanent part of the generator and should remain with the generator if resold.

## **SAFETY MESSAGES**

Your safety and the safety of others are very important. We have provided important safety messages in this manual and on the gasoline engine. Please read these messages carefully.

A safety message alerts you to potential hazards that could hurt you or others. Each safety message is preceded by a safety alert symbol  and one of three words: DANGER, WARNING, or CAUTION. These mean:



**You WILL be KILLED or SERIOUSLY HURT if you don't follow instructions.**



**You CAN be HURT if you don't follow instructions.**



**Your gasoline engine or other property could be damaged if you don't follow instructions.**

**XIV. EASY WORN PARTS AND ACCESSORIES LIST**

## Easy worn parts list:

Cylinder head cover gasket
Cylinder head gasket
Spark plug
Oil sealing
Breath groove gasket
Crankcase gasket
Recoil starter
Carburetor gasket
Carburetor insulation gasket
Insulation plate gasket
Air cleaner gasket
Exhaust vent gasket

## Accessories list :

Socket
Force bar

**CONTENTS**

PREFACE .....	1
SAFETY MESSAGES .....	2
I. SAFETY PRECAUTIONS .....	4
II. PARTS DESCRIPTION .....	6
III. E-OPEATE INSPECTION.....	9
IV. STARTING THE ENGINE .....	14
V. RUNNING THE ENGINE .....	17
VI. STOPPING THE ENGINE .....	18
VII. KIT HIGH ALTITUDE REPLACEMENT FOR EPA III ENGINES .....	19
VIII. EXHAUST CONTROL SYSTEM SERVICE .....	21
IX. MAINTENANCE .....	23
X. TRANSPORT AND STORAGE .....	27
XI. TROUBLESHOOTING .....	28
XII. SPECIFICATIONS .....	32
XIII. ELECTRIC DIAGRAM .....	33
XIV. SY WORN PARTS AND ACCESSORIES LIST .....	34

## I. SAFETY PRECAUTIONS

**⚠ DANGER** Indicate a possibility of invalid warranty and personal or equipment damage if instructions are not followed.

Please pay special attention to the following:

1. Strictly set the engine according to the regulated power on the owner's manual. Do not overload, overrun the engine or run it with low load and at low speed in a long time.
2. Use specified grade of gasoline. The fuel should be fully deposited and filtrated before use. Keep clean the fuel filler, change the oil periodically.
3. Periodically check the installation, connection and the degree of tightness of the fixed bolt. Tighten it if necessary.
4. Periodically clean the element of the air cleaner, change it when necessary.
5. The engine is air-cooled, so clean the radiator, wind cover and fan in time in order to make the engine cool normally.
6. The operator should be familiar with the working principle and structure of the gasoline engine, knowing how to make an emergent stop and the operation of all controlling parts. Any one without training is forbidden to operate the engine. Keep periodical maintenance. Solve problems in time. Do not run the engine in spite of malfunction.
7. Running the engine in a well-ventilated place, keep it at least one meter away from building walls or other equipments, keep away from inflammables such as gasoline, matches and so on to avoid possibility of fire.
8. Refuel in a well-ventilated area with the engine stopped, and in places refueling or storing gasoline, no smoking and any flames or sparks.
9. Refuel the fuel tank not too full so as to avoid fuel's spilling out. If there is spilled fuel around, be sure to clean it thoroughly before starting.
10. The exhaust from the engine may contain poisonous carbon

## XIII. ELECTRIC DIAGRAM

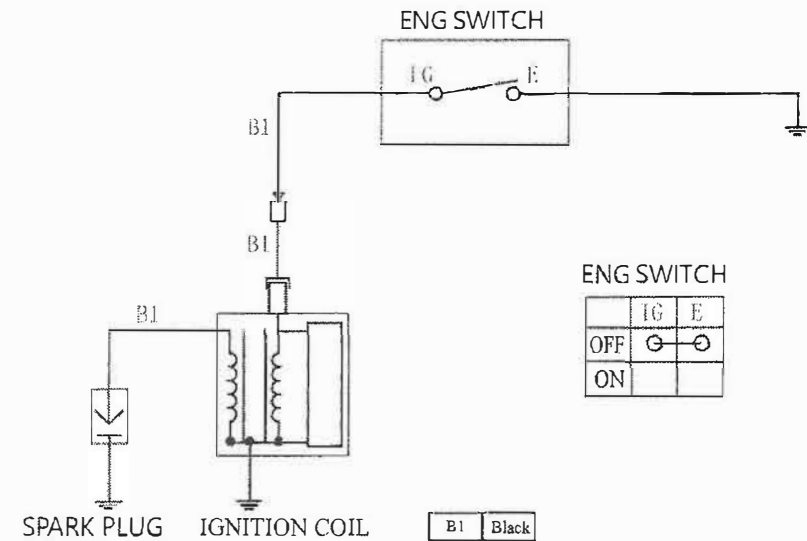

## XII. SPECIFICATIONS

### 1. Main Specification

Model	140	170	225
L×W×H(mm)	377×326.5×304	395×348×282	404×362×292
Dry Weight	13kg	14kg	15.5kg
Engine Type	single cylinder horizontal, 4-stroke, (OHV)		
Displacement	139.36ml	173.2 ml	223ml
Bore × Stroke	65×42mm	70×45mm	70×58mm
Theoretical Maximum Power	2.3kw/3,600r/min	3.2 kw/3,600r/min	4.1kw/3,600r/min
Recommended Using Power	Washer 1.9kw/3450r/min	3.0kw/3450r/min	3.5kw/3400r/min
	Lawn mower 1.3kw/2750r/min	1.8kw/3000r/min	1.8kw/2700r/min
	Mini tiller 1.6kw/3000r/min	2.5kw/3100r/min	3.0kw/2050r/min
Maximum Torque	6.3N·m/2,500r/min	9.0N·m/2,500r/min	12.5N·m/2,500r/min
Fuel Consumption	395g/kw·h		
Cooling System	Forced air		
Ignition System	capacitance discharge type		
PTO Shaft Rotation	vertical shaft output		

### Data Adjustment

Items	Technical data	Service
Spark plug clearance	0.7-0.8mm	To see P25
Carburetor idle speed	1900±100r/min	To see P26
Valve clearance (cold engine)	intake: 0.15±0.02mm	Serviced by our company authorized dealer
	exhaust: 0.20±0.02mm	



Specification is subject to change without notice. For further information, please contact our company dealer.

### 2. Torque Of Important Bolts

Items	Specifications	140		170/225	
		Torque valve		Torque valve	
		N·m	kg·m	N·m	kg·m
Connection-rod bolt	M7×32	12	1.2	M7×1.0	1.2
Cylinder head bolt	M8×50	25	2.5	M8×50	2.6
Flywheel nut	Aluminum M14×1.5 (special)	52	5.2	M14×1.5 (special)	5.2
	Cast Iron M14×1.5 (special)	78	7.8	M14×1.5 (special)	7.8
Crankcase cover bolt	M6×28	10	1.0	M8×50	2.6
Valve clearance adjusting nut	M6×0.5	10	1.0	M6×0.5	1.0
Valve-rocker bolt	M8×1.25	24	2.4	M8×1.25	2.4

monoxide. To avoid inhalation of CO, never run your engine in a poorly ventilated area.

- The exhaust muffler is very hot during running the engine even after the engine stops. Never touch it, or you may get burns. Transport or store the engine with it cooling down entirely.
- Do not allow children to use this engine. Keep children and pets away from the operating area.
- Safe warning label:

Please carefully read warning label before operating. Our company will not assume any responsibility for person hurt, or equipment damaged caused by disregarding this warning label.

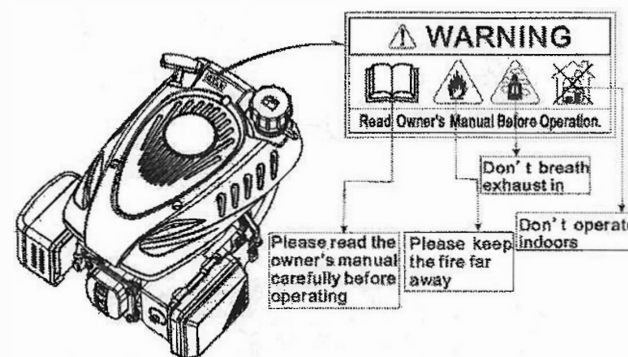

### 14. Exhaust label:

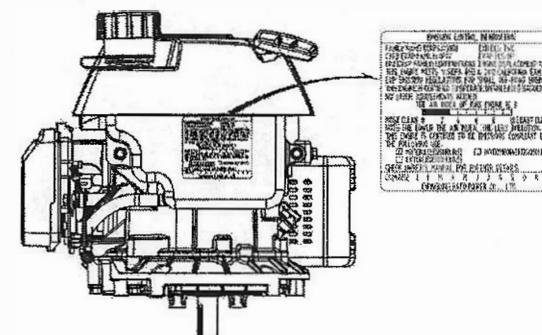

## II. PARTS DESCRIPTION

### 1. Feature

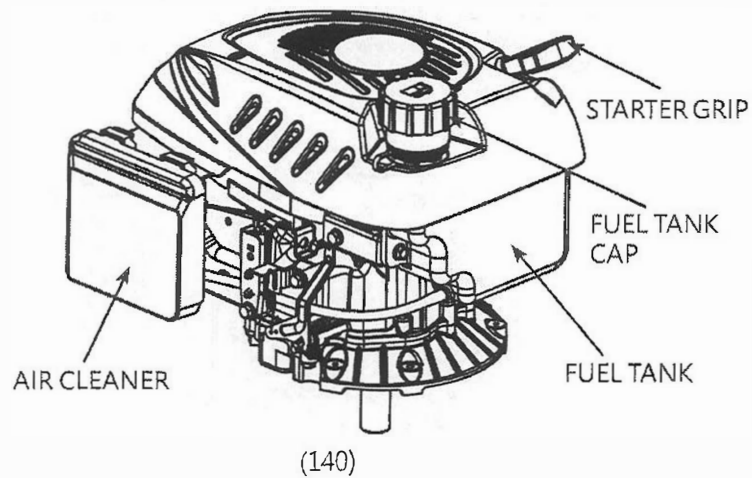
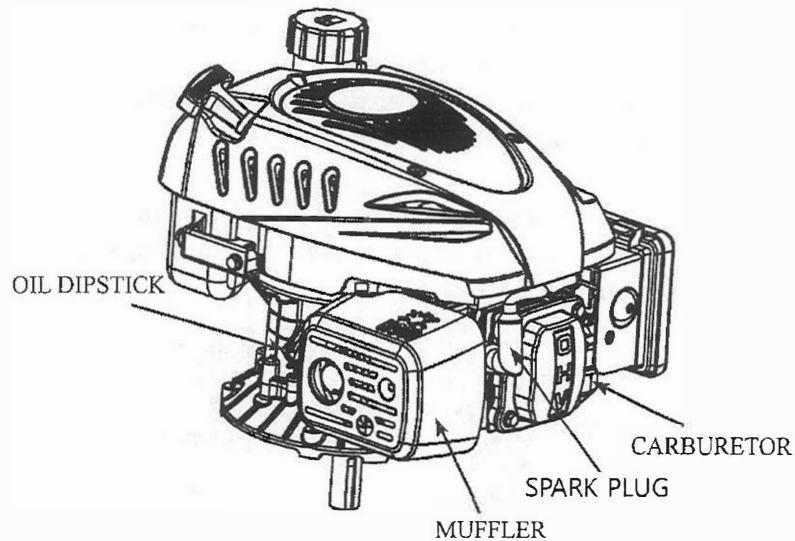

### 5. Gasoline Engine Is Overheat

TROUBLE	CAUSE	REMEDY
Gasoline engine is overheat	Oil insufficient or wrong oil ratio in the gasoline	Refill engine oil
	Exhaust pipe blocked up	Clean exhaust pipe
	Shroud leaking	Repair damaged part
	Cooling fins blocked by foreign matter	Clear cooling fins
	Connection rod deformation to make piston and cylinder bushing side wear	Replace connection rod
	Cylinder or piston or piston ring is worn to make hunting between cylinder and crankcase	Replace the worn parts
	Improper adjustment of engine governor to produce speed high.	Readjust engine governor
Crankshaft main bearing burnt out	Replace main bearing	

#### ⚠ CAUTION

The gasoline engine should be kept about 80 ~ 110°C temperature around the outlet of the shroud. If the temperature is too high, it will indicate the gasoline engine overheating.

### 6. Abnormal Noise Exist When Engine Running

TROUBLE	CAUSE	REMEDY
Beating sound	Piston, piston ring or cylinder is worn	Replace the worn part
	Connection rod or piston pin and piston pin hole are worn	Replace the worn part
	Crankshaft main neck is worn	Replace bearing
	Piston ring is broken	Replace piston ring
Metal beating sound when abnormal combustion occurs	Too much carbon deposit in combustion chamber	Clear away carbon deposit
	Improper fuel brand	Replace fuel
The other	Engine is overheat	Find a cause and eliminate it
	Improper valve clearance	Readjust valve clearance properly
	Fly wheel is not connected with crankshaft tightly	Connect tightly



3. Gasoline Engine Cannot Running Unsmoothly

TROUBLE	CAUSE	REMEDY
Knocking sound	Piston, cylinder or piston ring is worn excessively.	Replace the worn
	Piston pin and piston pin hole are worn excessively.	Replace piston or piston pin
	Tie rod small head is worn excessively.	Replace tie rod
	Roller bearing for crankshaft main shaft is worn.	Replace roller bearing
Abnormal combustion	Engine is too hot	Shoot trouble
	Too much carbon deposit in combustion chamber	Clear away
	Improper gasoline brand or gasoline quality	Replace with qualified gasoline
Spark lacking	There is water in float chamber	Clean
	Improper spark plug electrodes clearance	Adjust
	Something wrong with induced coil, and so	Check and replace damaged parts

4. Stop Suddenly When Running

TROUBLE	CAUSE	REMEDY	
Stop suddenly when running.	Fuel supply system	Fuel is finished	Refill fuel
		Carburetor is clogged	Check fuel line and dredge
		Float chamber is leaking	Repair
		Needle valve is stuck.	Dismantle float chamber and eliminate it
	Ignition system	Spark plug is punctured, or short-circuited by carbon deposit	Replace spark plug
		Side electrode of spark plug is dropped out	Replace spark plug
		High-tension wire is dropped out	Weld on
		Ignition coil is punctured or short-circuited	Replace ignition coil
		Parking wire is located on engine body	Find out meeting and insulate
	The other	Cylinder is seriously scored and valve dropped out	Repair or replace damaged parts

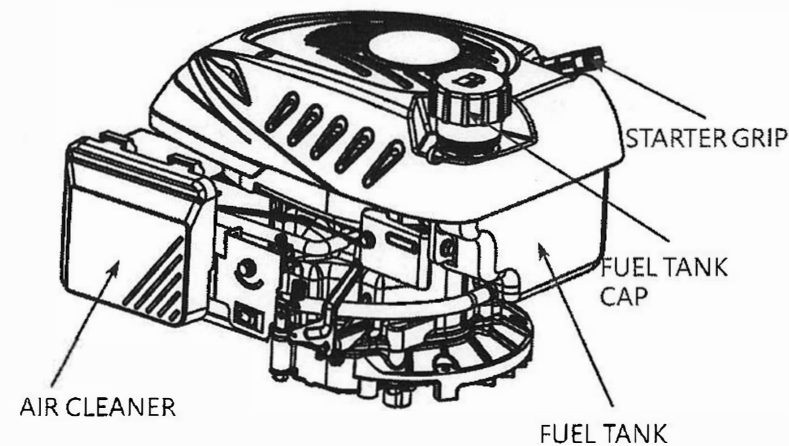
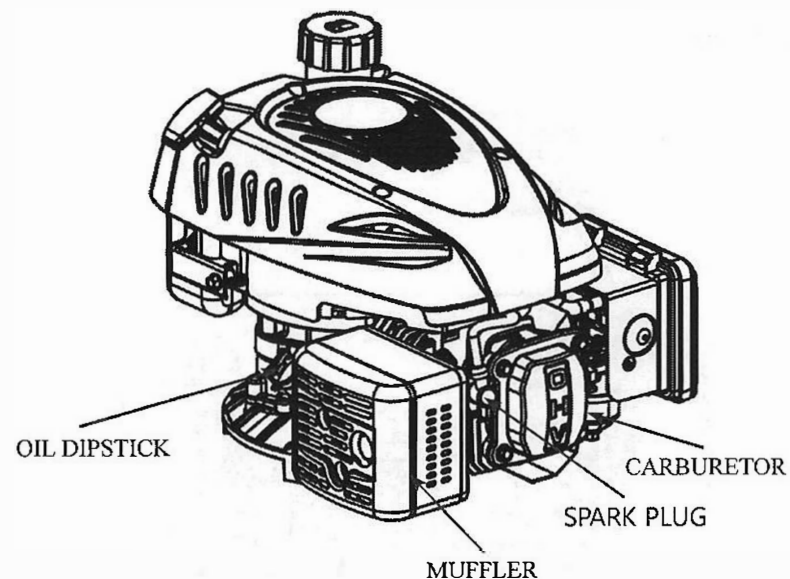

(170 225)

2. Model No.

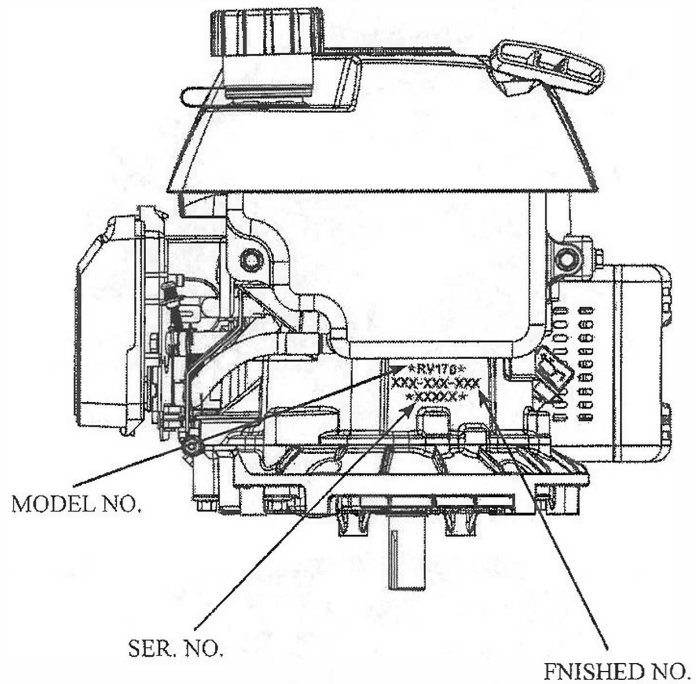

If still can't starting, have the engine to our authorized dealer for repairing.

**⚠ WARNING**

- When testing the spark plug, never hold the high-voltage wire of the spark plug with wet hand.
- Make sure there is no spilled fuel outside the engine and that the spark plug isn't dipped with fuel.
- To prevent fire, keep sparks far away from the spark plug mounting hole.

2. Gasoling Engine Power Output Insufficiency

TRU- BLE	CAUSE	REMEDY	
When increasing throttle, speed increase slow or even decrease and stop running	Fuel supply system	Air in fuel line or fuel line clogged.	Exhaust air or dredge fuel line
		Main oil flow hole is not adjusted properly	Readjust
		In carburetor, needle valve hole and main oil flow hole clogged.	Clean and blow to get through
		Fuel cock is clogged up.	Clean, replace damaged part
		Too much carbon deposit in combusting chamber.	Clear away
		Too much carbon fouling in muffler and exhaust pipe.	Clear away
		Air cleaner is clogged up.	Clean air cleaner filter element
	Poor compression	Intake pipe is leaking	Repair or replace
		Piston or cylinder or piston ring is worn	Replace the worn
		Air leakage from the surface by which cylinder block contacting with cylinder head.	Replace cylinder gasket
	Too big or too small valve clearance.	Readjust	
	Valve tightness is poor.	Repair	



4) Reinstall the dipstick.

## X. TRANSPORT AND STORAGE

### CAUTION

**Do not incline the engine so as to avoid fuel's spill in transporting. Spilled fuel or fuel vapor may ignite to cause fire. If suspension for a long time, storage should be as following:**

1. The storage area is dry and free of dust.
2. Completely drain fuel out of the fuel tank and carburetor.

### WARNING

**Fuel is extremely flammable and explosive under certain conditions. Keep smoke, fire and spark away from operating site.**

3. Replace engine oil.
4. Remove the spark plug. Fill about a spoon of fresh engine oil onto the cylinder. Crank the engine up to distribute engine oil evenly. Reinstall the spark plug.
5. Lightly pull the recoil starter rope until the resistance is felt. Close the choke to protect the dust from entering in.
6. Cover the engine to protect dust entering.

- (1) Remove the spark plug cap.
- (2) Clear away dirt around the spark plug base.
- (3) Dismantle the spark plug with a spark plug wrench.
- (4) Visually check the spark plug. Clean with a steel brush. If the insulator is damaged, replace the spark plug instead.
- (5) Measure the spark plug clearance with a feeler. The clearance should be 0.7~0.8mm. If adjustment is necessary, bend the side electrode carefully.
- (6) To avoid cross-threading, first, screw in spark plug by hand, then tighten with a spark plug wrench to compress the gasket.
- (7) If a new spark plug is used, please replace it with same spark plug model as can as possible, and more twist 1/2 turns after compressing the gasket.
- (8) If reinstalling the used spark plug, just more twist 1/8-1/4 turns.

**CAUTION**

- (1) **The spark plug must be tightened securely, or it may become very hot to damage the engine.**
  - (2) **Only use recommended spark plug or the equivalent. Incorrect heat range of the spark plug may damage the engine.**
- 4) Idle speed adjustment of the carburetor
- (1) Start the engine and preheat it to normal operating temperature.
  - (2) Adjust the throttle stopping screw to obtain minimum idle speed.
- Minimum idle speed:(1,900±100) r/min.

**Engine oil change:**

**CAUTION**

Used engine oil may cause skin cancer if repeatedly left in contact with the skin for prolonged periods. It is still advisable to thoroughly wash your hands with soap and water as soon as possible after handling used oil. Please dispose of used engine oil in a manner that is compatible with the environment.

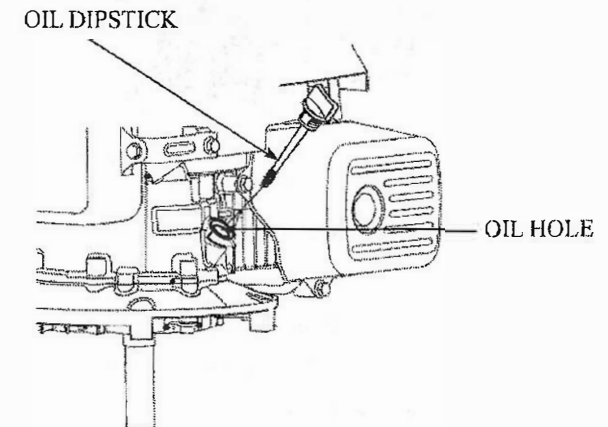

- 1) Screw the oil dipstick out.
- 2) Tilt the gasoline engine and let the oil overflowing out from the hole.

## 2. Air Cleaner



Never run the engine without an air cleaner, or severe wear of the engine may be resulted in.

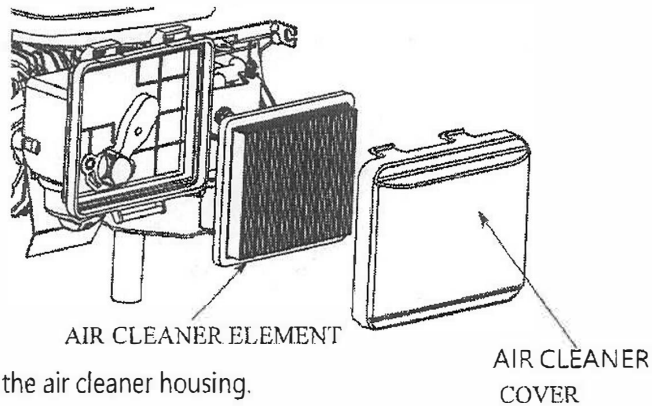

- 1) Remove the air cleaner housing.
- 2) Remove foam element or paper element, paying attention to prevent dust and foreign matter entering into air cleaner.
- 3) Check, clean or replace damaged air cleaner parts.
- 4) Reinstall the air cleaner parts back.

## 3. Fuel Check

- 1) Remove the fuel tank cap and check fuel level.
- 2) If the level is too low, refuel the tank. Remember adding fuel not over the fuel upper level.

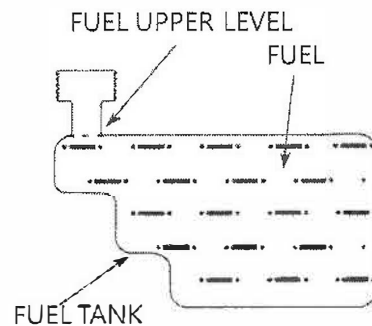

Never clean the air cleaner element with gasoline or low flash-point detergents, or explosion may happen.



Clean the foam filter with soapy water, blow the paper element with compressed air or lightly tap off dust and never dry to brush .



- (1) Gasoline is extremely flammable and explosive in certain condition. Keep cigarette, sparks and fire away.
- (2) After reinstalling the deposit cup, don't start the engine until the area around is dry.

## 3) Maintenance of spark plug

In order to ensure the engine normal running, gap of the spark plug must be correct and no deposit around the spark plug.

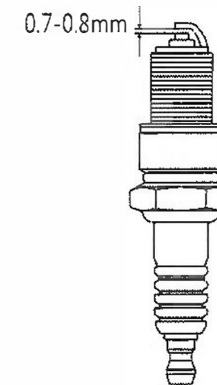

Spark recommended using plug model  
 NGK: BP6ES(140)  
 NHSP: F6RTC/R6TC(140)  
           F7RTC/F7TC(140)  
 TORCH: F7RTC/F7TC(140)  
           F6RTC/R6TC(140)  
           DK7RTC\DK7TC(170/225)



Don't touch the muffler to avoid burn in the engine running or just stopping a moment.

## 2. Maintenance Method

### 1) Replacement of engine oil

Drain the engine oil rapidly and completely out when the engine is hot.

- (1) Remove the oil dipstick, drain plug and washer and drain engine oil thoroughly. Reinstall the drain plug and screw in it securely.
- (2) Fill the recommended engine oil and check oil level with oil dipstick.
- (3) Reinstall the oil dipstick and tighten it securely.



**Please dispose of used engine oil and the oil containers in a manner that is compatible with the environment. We suggest you take used oil in a sealed container to your local recycling center or service station for reclamation. Do not throw it in the trash or pour it on the ground or down a drain.**

### 2) Maintenance of air cleaner

A dirty or damaged air cleaner will allow dust entering into the engine, causing rapid engine wear. So, service the air cleaner in time.

- Remove the bolt and air cleaner cover. Be careful to prevent dirt and debris from falling into the air cleaner base opening.
- Remove the foam element or paper element.
- Check, clean or replace the damaged air cleaner parts.
- Reinstall the air cleaner parts, then bolt and screw down it.



- 1. Gasoline is extremely flammable and is explosive under certain conditions.**
- 2. Refueling in a well-ventilation area with the engine stopped. Do not smoke and allow flames or sparks in the area where gasoline is stored or where the fuel tank is refueled.**
- 3. Do not overfill the fuel tank (there should be no fuel in the filling neck). After refueling, make sure the fuel tank cap is set back securely.**
- 4. Be careful not to spill fuel when refueling. Spilled fuel or fuel vapor may ignite. If any fuel is spilled, make sure the area is dry before starting the engine.**
- 5. Avoid repeated or prolonged contact with skin or breathing of fuel vapor. Keep out of reach of children.**

Fuel tank capacity: 1.0L

Only use unleaded gasoline and recommend gasoline grade 90#over.

Unleaded gasoline can reduce gasoline engine carbon deposit and prolong the exhaust system service life.

Never use contaminated gasoline or mixed gasoline with oil. Don't allow the dust, foreign matter or water entering into fuel tank.

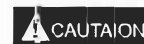

**Fuel may damage the oil paint and plastic. Be careful not to spill fuel when refueling. Any damage due to oil spilling is not within valid warranty.**

"Light knocking" or "spark exploding" sound can be heard when the engine overloading. It is normal. Do not worry about that.

If "knocking" or "spark exploding" sound occur at a steady speed under normal load, change brand of gasoline; if such phenomena still happen, consult your dealer for help, otherwise the engine may be damaged.

When the engine is running, continuously "Knocking" or "spark exploding" sound occurring will damage engine.

"Knocking" or "spark exploding" sound from misusing will not be within the valid warranty.

## IX. MAINTENANCE

### 1. Maintenance Schedule

In order to keep the engine well, must periodically service and adjust the engine. Service shall be as following schedule.

MAINTENANCE SCHEDULE

Item	Frequency	Each time	First month or 20 hrs	Each season or 50 hrs	Every 6 month or 100 hrs	Each year or 300 hrs
Engine oil	Oil level check	√				
	Replace (Note)		√	√		
Air cleaner	Check	√				
	Clean		√			
Replace air cleaner element				√		
Spark plug	Clean, adjust				√	
	Replace					√
Oil strainer	Clean				√	
Valve clearance	Check adjust					√*
Cylinder head	Clean					√*
Fuel tank	Replace	Every three years				

\*Note 1: Initial oil change should be performed after first twenty hours of operation. Thereafter change oil every fifty hours. Dispose of waste oil safely and responsibly. Do not pour into sewage drains, onto garden soil or into open streams. Your local zoning or environmental regulations will give you more detailed instructions on proper disposal.

\* These items should be serviced by company authorized dealer, unless you have the proper tools and mechanically proficient.

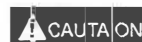

Service more frequently when used in dusty areas.



- 2) Altering or defeating the governor linkage or speed-adjusting mechanism to cause the engine to operate outside its design parameters.

#### 4. Problems Affecting Exhaust Emissions

- 1) Difficult starting or difficult stopping.
- 2) Unstable idle speed.
- 3) Give off black smoke or consume too much fuel.
- 4) Poor ignition sparks or sparks returned.
- 5) Too early ignition.

## IV. STARTING THE ENGINE

1. Starting method:

- A. Turn the throttle lever and brake lever along with direction of arrow to bottom. ("OPEN" position), As shown as following.

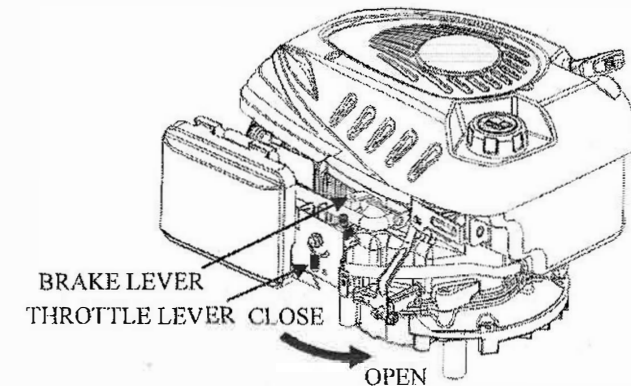

- B. Turn the throttle lever along with direction of arrow to bottom. ("OPEN" position) and turn the engine stop switch to "ON" state as shown as following.

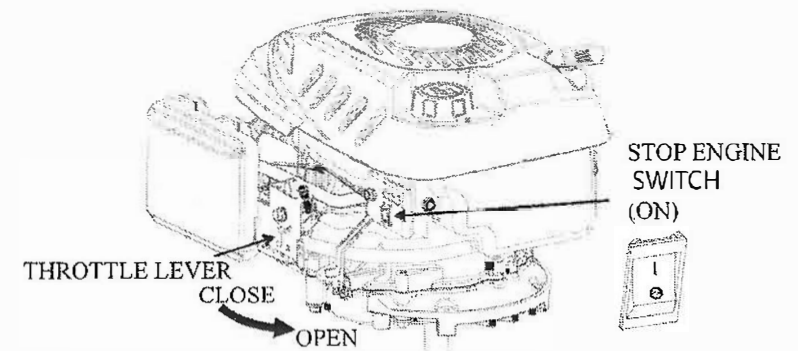

- C. Put the choke cable to “OPEN” position and turn the engine stop switch turn to “ON” position at the same time as shown on the following drawing:

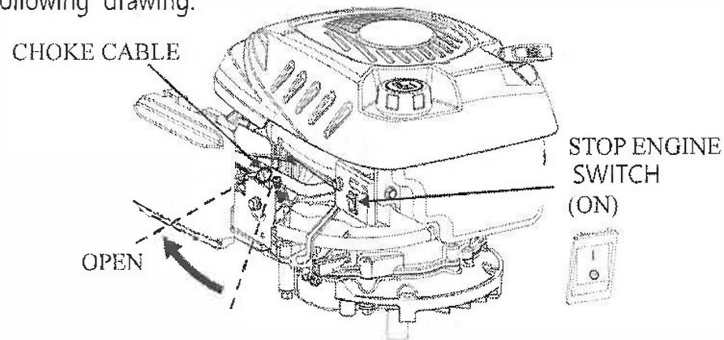

**CAUTION**

**Don't pull the throttle level if the gasoline engine is hot. Assemble the choke cable according to user requirement.**

- D. Starting primer gasbag operation is important operation of the starting engine. Turn the stop engine switch to “ON” state. For cold starting, slightly press the primer gasbag three to five times in succession and quickly pull the recoil cable grip. For hot starting, directly pull the starter cable grip.

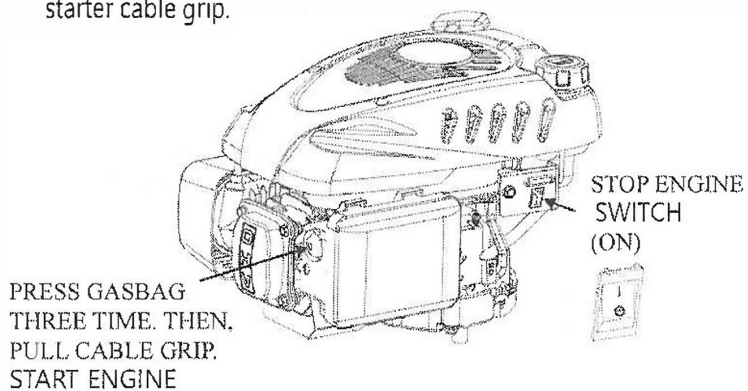

systems.

## 2. STARTING THE ENGINE

Pull the starter grip lightly until resistance is felt, then, briskly pull to syncline upper 30 degree out.

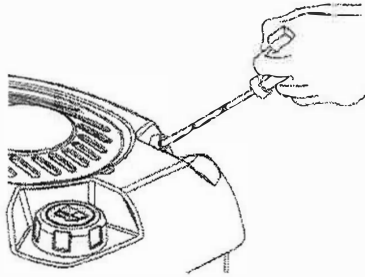

### NOTICE

**Don't allow the starter grip to snap back against the engine. Return it gently to prevent damage to the starter**

## VIII. EXHAUST CONTROL SYSTEM SERVICE

With the engine running, carbon monoxide, oxide of nitrogen and hydrocarbon will produce, and in certain conditions, oxide of nitrogen and hydrocarbon will react chemically each other to make smoke while carbon monoxide is toxic, so exhaust control of them is very important. The company decreases the exhaust emissions by introducing poor-fuel carburetors and other devices into the engine to solve the problem.

To keep the exhaust of your engine with in the standard exhaust emission, pay attention to the following:

### 1. Maintenance

Maintain the engine periodically in accordance with the maintenance schedule in the manual. The maintenance schedule is made out on the base of normal use in normal conditions, if using under heavy load, dusty or wet circumstances or in high temperature, service of the engine should be done more often.

### 2. Replacing Parts

To ensure the best quality and reliability, use only new genuine our company parts or their equivalents for repair and replacement.

### 3. Tampering and Altering

Tampering with or altering the emission control system may increase emissions beyond the legal limit. Among those acts that constitute tampering are:

- 1) Removal or alteration of any part of the intake, fuel, or exhaust

If a carburetor is replaced, the proper high altitude kit jet will need to be installed into the replacement carburetor.



**WARNING!** To prevent serious injury from fire: Follow the kit procedures in a well-ventilated area away from ignition sources. If the engine is hot from use, shut the engine off and wait for it to cool before proceeding.

**NOTICE:** The warranty may be void if necessary adjustments are not made for high altitude use. To install a high altitude kit.

## V. RUNNING THE ENGINE

1. After starting, push the choke lever in the direction of the arrow to bottom.
2. After preheating the engine a period of time, you can fix a load.

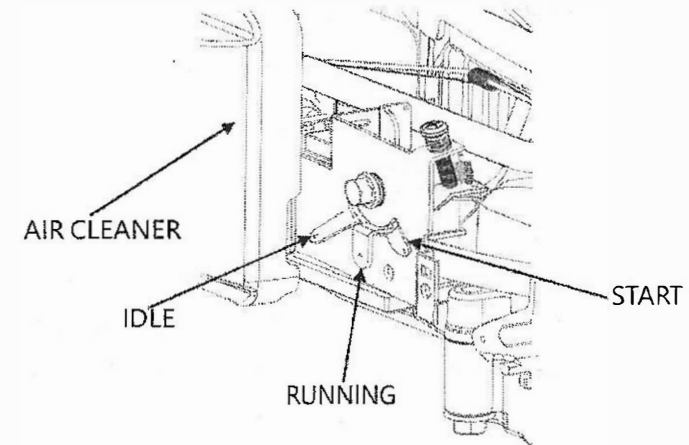

3. Pull the choke cable from the "OPEN" position to "RUNNING" position after starting engine.
4. Change the engine speed by adjusting the governor screw. For high speed, turn clockwise, and for low speed, turn counterclockwise. Please operate carefully. If you have any question, please contact our company authorized dealer unless the user have the proper tool and professional ability.

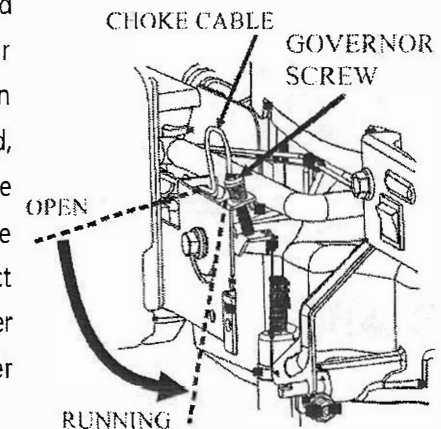

## VI. TOPPING THE ENGINE

1. Slowly turn the throttle lever to "IDLE" position

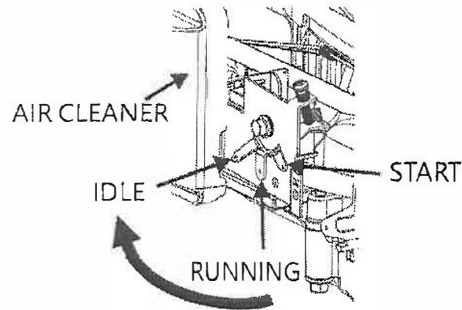

2. If the engine is controlled by brake lever, only turn the brake lever to "CLOSE" position for stopping engine ( as shown on the following Fig.1)  
If the engine is controlled by engine stop switch, For stopping the engine, directly turn the stop engine switch to "0" position (as shown on the following Fig.2) or press down the "STOP" for 5 seconds over by first finger, then loosen it (as shown on the following Fig.3).  
The engine stop engine is device of the opening and closing ignition circuit. (as shown on the following Fig.2)

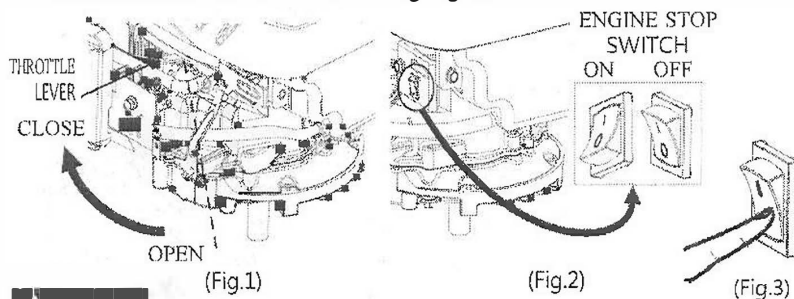

**CAUTION**

**Sudden stopping at high speed under heavy load is forbidden, otherwise damage will result.**

## VII. IT HIGH ALTITUDE REPLACEMENT FOR EPAIII ENGINES

3000ft to 6000ft or 6000ft to 8000ft of elevation

\* At high altitude, the standard carburetor air-fuel mixture will be too rich. Performance will decrease and fuel consumption will increase. A very rich mixture will also foul the spark plug and cause hard starting. Operation at an altitude that differs from that at which this engine was certified, for extended periods of time, may increase emissions.

\* The fuel system on this Engine or Equipment may be influenced by operation at higher altitudes. Proper operation can be ensured by installing an altitude kit when required. See the table below to determine when an altitude kit is required. Operating this generator without the proper altitude kit installed may increase the engine's emissions and decrease fuel economy and performance. Kits may be obtained from any Dealer, and should be installed by a qualified individual.

Fuel	Altitude Range · ·	Kit Part Number
Gasoline	0 – 3000 ft	Not Required
	3000 – 6000 ft	Altitude kit 1#
	6000 – 8000 ft	Altitude kit 2#

\* Engine, Generator Set, Pressure Washer, Walk-Behind Lawnmower, Compressor, Pump, Tiller etc.

· · Elevation above sea level.

\* This high altitude jet is to be used at elevations above 3000 feet.

\* At elevations above 8000 feet, the engine may experience decreased performance, even with the high altitude kit.